

BB86 & BB92 Press fit Bottom Bracket Installation Instructions

Published - Oct, 2021. ZS114E.v0 © Full Speed Ahead

WWW.FULLSPEEDAHEAD.COM

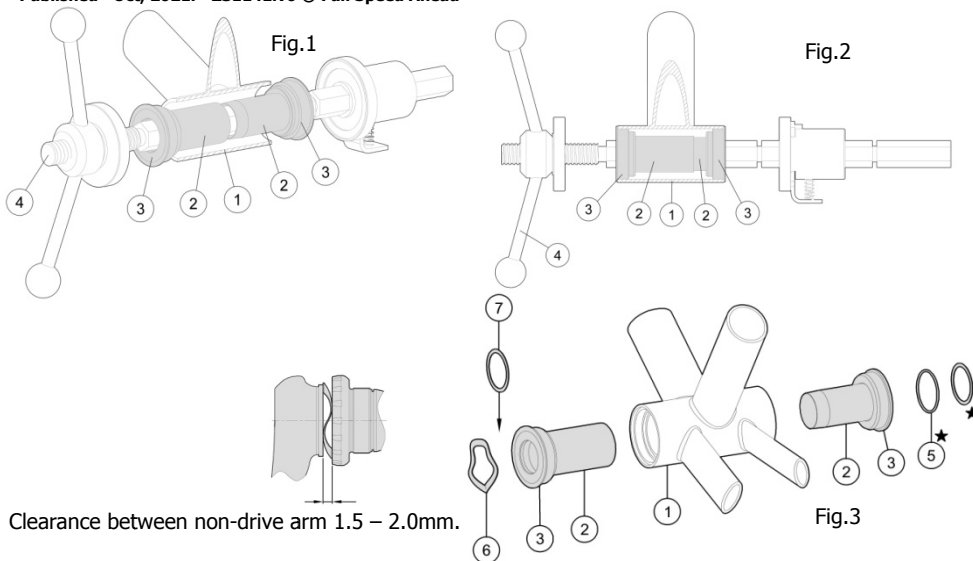

Clearance between non-drive arm 1.5 – 2.0mm.

BB86 & BB92 Press Fit Bottom Bracket Installation

1. Ensure that Bottom Bracket (BB) shell ① is clean and free of metal chips, dirt and excess paint. Bottom Bracket (BB) shell ID is $\varnothing 41+0/-0.05$ mm. Note: BB86 is for Road and BB92 is for MTB cranksets only.
2. Place Bearing cup ③ with plastic sleeve ② on the Headset press tool ④. Note: Right and Left bearing cups are the same.
3. Slide the Headset Press tool ④ through the Bottom bracket Shell ① and place the remaining Bearing Cup ③ with Plastic sleeve ② facing the Bottom bracket shell (Fig.1).
4. Using the Headset Press tool ④ press the bearing cups ③ with Plastic Center Sleeve ② into the BB shell. Tighten until the thrust face of the Bearing Cup ③ is flush with the outer face of the Bottom Bracket shell ① (Fig.2). Note: Be certain that the bearing cups and tool faces are aligned and square otherwise damage to the plastic covers and bottom bracket shell may occur.
5. When Bottom Bracket is fully installed unscrew Headset Press tool and carefully remove from the Bottom bracket.
6. Check bearings for rotational smoothness. If bearings feel rough, or not smooth, it may be an indication the Bottom Bracket (BB) shell ID is smaller or not true round. If the cups are not perfectly aligned in the bottom bracket shell, it may cause difficult to insert spindle during crankset installation. It may be necessary to remove and reinstall the bearings to be assured bearing alignment in the bottom bracket shell.

Note : Follow assembly order for spacer ⑦ and seal ⑤ as above illustration. Follow the crankset installation instruction for crankset will be installed. If use FSA Road MegaExo Cranksets no need to add ⑤ MS150 Seal.

⚠ CAUTION The wave spring washer does not have to be completely compressed for proper use but does have to be in contact on both sides of the left arm and left bearing shield in order to provide correct bearing preload to the bottom bracket. Clearance between non-drive arm and bearing shield 1.5 - 2.0mm. If the wave spring washer is not providing any bearing preload, and there is lateral play in the crank system. **⚠ WARNING** DO NOT tighten the crank bolt further. Remove crankset and bottom bracket and inspect bottom bracket shell for proper tolerances and repeat crank and bottom bracket installation. The spacer ⑦ may be used only on frames with slightly undersized BB shells width.

Introduction

Congratulations on your Full Speed Ahead product. Please read these instructions and follow them for correct use. Failure to follow the warnings and instructions could result in damage to product not covered under warranty, damage to bicycle; or cause an accident resulting in injury or death. Since specific tools and experience are necessary for proper installation, it is recommended that the product be installed by a qualified bicycle technician. FSA & Vision assumes no responsibility for damages or injury related to improperly installed components.

Warranty

Full Speed Ahead (FSA) warrants all FSA and Vision products to be free from defects in materials or workmanship for a period of two years after original purchase unless otherwise stated in the full warranty policy. The warranty is non-transferable and valid to the original purchaser of the product only. Any attempt to modify the product in any way such as drilling, grinding, and painting will void the warranty. For more information on warranty policy and instructions for completing a warranty claim, check out the Full Warranty Policy found at our website:

<https://www.fullspeedahead.com/en/technology>

Components

Follow the assembly order in the illustration:

- | | |
|-------------------------------------|-------------------------|
| ① Bottom Bracket Shell | ⑤ MS150 Seal x1 |
| ② Plastic Center Sleeve x1 | ⑥ Wave Spring Washer x1 |
| ③ Bearing Cup x2 | ⑦ MS318 Spacer x1 |
| ④ Headset Press Tool (not included) | |

Specification

Model Name /Item Number

BB86 Composite Cups	BB-CF86/SLE/CZ	for use with FSA Road MegaExo Cranksets
	BB-AL86/SLE/CZ/ $\varnothing 19$	for use with FSA Omega Road MegaExo Cranksets (spindle $\varnothing 19$)
BB86 Alloy Cups	BB-CF86/SLE	for use with FSA Road MegaExo Cranksets
	BB-AL86/SLE/ $\varnothing 19$	for use with FSA Omega Road MegaExo Cranksets (spindle $\varnothing 19$)
BB92 Composite Cups	BB-CFM92/SLE/CZ	for use with FSA MTB MegaExo Cranksets
BB92 Alloy Cups	BB-CFM92/SLE	

Model Name	Item Number	⑤ MS150 Seal	⑦ MS318 Spacer	BB Shell Width
BB86 (Road)	BB-CF86/SLE/CZ	1	1	86.5mm
	BB-CF86/SLE	1	1	86.5mm
	BB-AL86/SLE/CZ/ $\varnothing 19$	0	0	86.5mm
	BB-AL86/SLE/ $\varnothing 19$	0	0	86.5mm
BB92 (MTB)	BB-CFM92/SLE/CZ	0	1	92mm
	BB-CFM92/SLE	0	1	92mm

★ BB86 is compatible to Shimano crankset and need to add ⑤ MS150 Seal.

★ BB92 is compatible to MTB the BB shell width 89.5mm, need a 2.5mm spacer (MW112) at drive side; not included with FSA BB92 Kit.

聯絡方式

若有任何問題, 請上技術網頁: <https://www.fullspeedahead.com/en/support> 或聯絡:

Full Speed Ahead, USA
12212 Cyrus Way Mukilteo, WA 98275-5702
Tel: 1_425_488_8653 Fax: 1_425_489_1082

Full Speed Ahead, Europe
Via Del Lavoro, 56 20874 Busnago, Milan, Italy
Tel: +39_039_688_5265 Fax: +39_039_682_3336

TH INDUSTRIES / FSA Asia
NO.6, Wu-gong 8th Rd., Wufeng Dist., Taichung City 41353, Taiwan (R.O.C.)
Tel: +886_4_2331_9134 Fax: +886_4_2331_9314