

# ROAD/AGX Crankset Installation Instructions

Published – Jun, 2024. ZS233.v2 © Full Speed Ahead

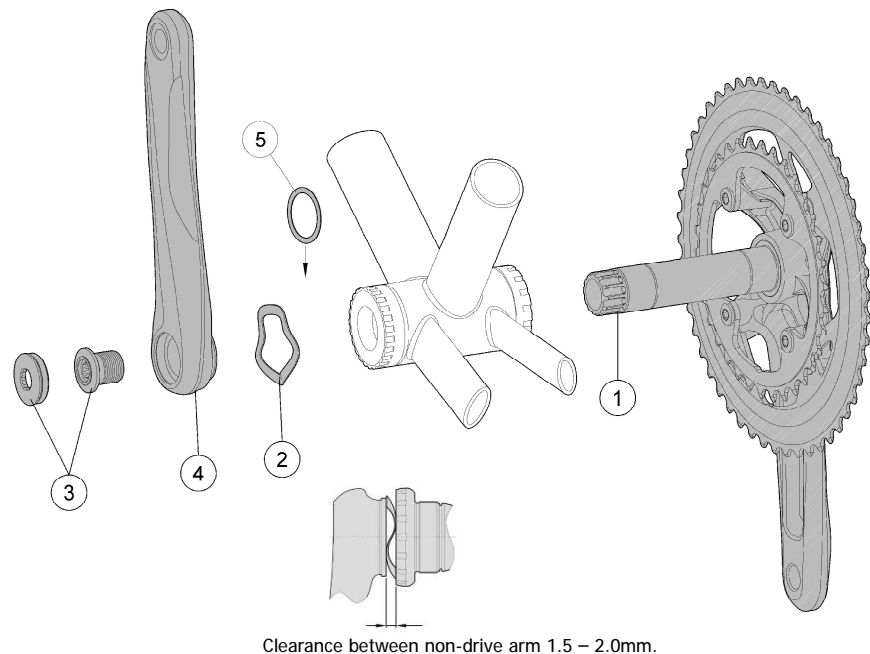

Clearance between non-drive arm 1.5 – 2.0mm.

## Crankset Installation

1. This instruction refers to installing the FSA MegaExo Road / AGX Crankset into a compatible frame. For BB installation refer to BB instruction to ensure crankset and bottom bracket compatibility before proceeding.

2. Install the Right Crank ①. Lightly grease the spindle bearing contact surface and insert from drive side.

**CAUTION** Take care not to damage plastic bearing covers during Crank Spindle ① installation.

3. Apply grease to the spindle splines. Place wave washer ② onto the spindle ①.

4. Install the Left crank arm ④ onto the spindle ①. Tighten the QR Self extracting crank bolt ③ to 388-418 kgf.cm / 38-41 Nm / 336-363 in.lbs.

**CAUTION** Do not tighten crank bolt over 418 kgf.cm / 41 Nm / 363 in.lbs. Do not completely flatten the wave spring washer ②. The gap between left crank arm and left bearing cup should be 1.5 - 2.0mm. If the gap is not within 1.5 - 2.0mm after applying correct torque. DO NOT tighten the crank bolt further. Recheck installation procedure and order of assembled parts. Ensure correct torque is used. The 0.5mm spacer ⑤ may be used only on frames with slightly undersized BB shells.

**WARNING** Always use a calibrated torque wrench to tighten crank bolt ③. Check bolt torque 388-418 kgf.cm / 38-41 Nm / 336-363 in.lbs before each ride to ensure they have not loosened during use.

## Introduction

Congratulations on your Full Speed Ahead product. Please read these instructions and follow them for correct use. Failure to follow the warnings and instructions could result in damage to product not covered under warranty, damage to bicycle; or cause an accident resulting in injury or death. Since specific tools and experience are necessary for proper installation, it is recommended that the product be installed by a qualified bicycle technician. FSA & Vision assumes no responsibility for damages or injury related to improperly installed components.

## Warranty

Full Speed Ahead (FSA) warrants all FSA and Vision products to be free from defects in materials or workmanship for a period of two years after original purchase unless otherwise stated in the full warranty policy. The warranty is non-transferable and valid to the original purchaser of the product only. Any attempt to modify the product in any way such as drilling, grinding, and painting will void the warranty. For more information on warranty policy and instructions for completing a warranty claim, check out the Full Warranty Policy found at our website: <https://www.fullspeedahead.com/en/support/warranty-policy>

## Specification

Model Name	Gossamer Pro MegaExo
Model Name	Omega Direct Mount MegaExo $\Phi$ 19
Model Name	Omega Direct Mount MegaExo AGX $\Phi$ 19
Model Name	Omega MegaExo $\Phi$ 19

## Components

Follow the assembly order in the illustration

- ① Right Crank w/spindle x1
- ② Wave Washer x1
- ③ QR Self-Extracting Crank Bolt Assembly (Pre-installed on left crank)
- ④ Left crank x1
- ⑤ 0.5 mm Spacer x1

★ Components ② and ⑤ included with Gossamer Pro 24mm spindle cranks only

## 聯絡方式

若有任何問題, 請上技術網頁: <https://www.fullspeedahead.com/en/support> 或聯絡:

Full Speed Ahead, USA  
12212 Cyrus Way Mukilteo, WA 98275-5702  
Tel: 1\_425\_488\_8653 Fax: 1\_425\_489\_1082

Full Speed Ahead, Europe  
Via Del Lavoro, 56 20874 Busnago, Milan, Italy  
Tel: +39\_039\_688\_5265 Fax: +39\_039\_682\_3336

TH INDUSTRIES / FSA Asia  
NO.6, Wu-gong 8th Rd., Wufeng Dist., Taichung City 41353, Taiwan (R.O.C.)  
Tel: +886\_4\_2331\_9134 Fax: +886\_4\_2331\_9314